

TECHNICAL CARD

ELEMENTS 3E EKO+

Elements designed for the erection of single-layer structural walls.



ECO-FRIENDLY CONSTRUCTION

THE JOINTLESS SYSTEM COMPRISES 70 TYPES OF ELEMENTS GROUPED ACCORDING TO THEIR PURPOSE.

6 BASIC ELEMENTS

DIMENSIONS OF THE BASIC ELEMENT

S1 WP

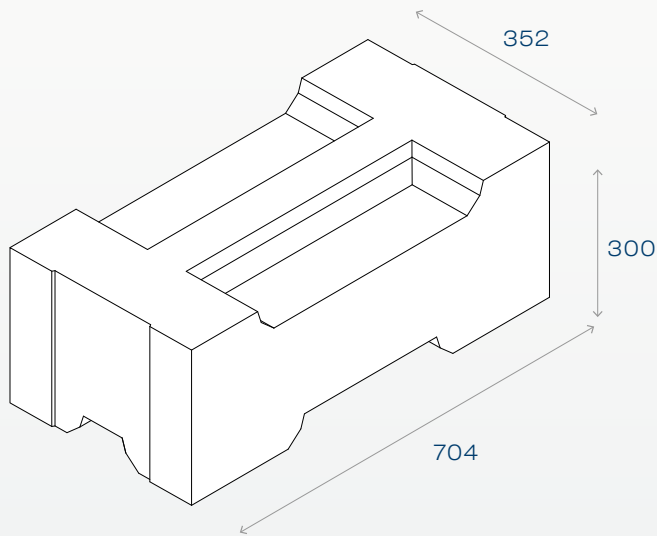

Deviations:
 Flatness of the laying surface: $\leq 1,0$ mm
 Parallelism of the laying surface: $\leq 1,0$ mm
 Mass of a single piece: 32 kg/el.

D4

Declaration of Performance (DoP) S3E EKO+.../01/23

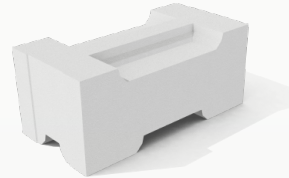

BASIC ELEMENT **S1 WP**
purpose: infill

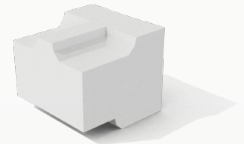

HALF ELEMENT **S½ W**
purpose: infill

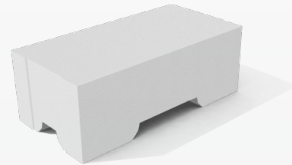

ENDING ELEMENT **SZ/EO WP**
purpose: top structure end



STARTING ELEMENT **SO WP**
purpose: foundation slab surface

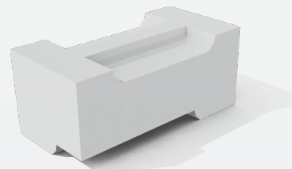

LEFT CORNER ELEMENT **SNL**
purpose: corner laying

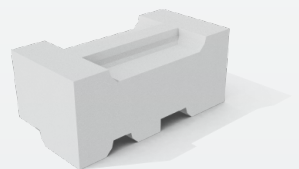

LEFT CORNER ELEMENT **SNP**
purpose: corner laying

SYSTEM 3E EKO+ is currently the warmest material for building:

- ✓ energy-saving
- ✓ zero-energy
- ✓ plus-energy
- ✓ passive houses



WITHOUT INSULATION



BONDING WITHOUT MORTAR AND GLUE



CONSTRUCTION OF 1 m² WALL IN 4.5 MINUTES

U=0,198 W/m²K

Building time comparison of a 1 m² wall

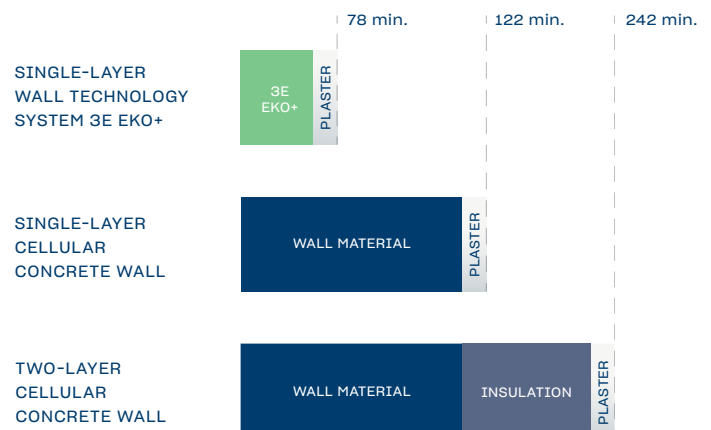

TECHNICAL CARD

ELEMENTS 3E EKO+

Elements designed for the erection of single-layer structural walls.



ECO-FRIENDLY
CONSTRUCTION

PERFORMANCE CHARACTERISTICS

Density	310 ± 10% kg/m ³
Characteristic compressive strength	≥ 1,5 N/mm ²
Water absorption due to capillary rise	after 10': ≤ 40 g/m ² · s ^{0,5}
Dimensional stability. Moisture expansion	≤ 0,30 mm/m
Reaction to fire	A1
Water vapour permeability, diffusion resistance factor	≤ 15
Freeze/thaw durability	20 cycles

Source: Technical recommendation SYSTEM 3E EKO+ RT2023/03/01

TECHNICAL CONSTRUCTION PARAMETERS

Characteristic compressive strength of masonry	$f_k = 1,02 \text{ N/mm}^2$
Characteristic value of the tensile strength (when the upper edge is restrained) at bending in the case of failure in the perpendicular plane	$f_{xk \perp} = 0,11 \text{ N/mm}^2$
Characteristic value of the tensile strength (when the upper edge is restrained) at bending for failure in the parallel plane	$f_{xk \parallel} = 0,31 \text{ N/mm}^2$
Characteristic shear strength of masonry	$f_{vk} = 0,07 \text{ N/mm}^2$

Source: Technical recommendation SYSTEM 3E EKO+ RT2023/03/01

LOGISTICAL DATA

Consumption of 1 m ²	5,71 el./m ²
Wall area per pallet	4,2 m ²
Number of elements per pallet	to 24 el.
Approximate weight of the pallet	800 - 900 kg
Weight of a single element	32 kg/el.
Weight of 1 m ²	182,7 kg/m ²

THERMAL PROPERTIES

Thermal conductivity coefficient (λ)	0,072 W/(m·K)
Thermal resistance coefficient R	4,89 (m ² K)/W
Heat transfer coefficient for unrendered walls U	0,198 W/(m ² K)
Heat transfer coefficient for rendered walls U*	0,196 W/(m ² K)

Source: Technical recommendation SYSTEM 3E EKO+ RT2023/03/01
*Wall covered with 1 cm thick gypsum plaster ($\lambda=0,39 \text{ W/(m}^2\cdot\text{K)}$) on the inside and with 1 cm thick cement-lime plaster ($\lambda=0,46 \text{ W/(m}^2\cdot\text{K)}$) on the outside

ACOUSTIC PROPERTIES

	$R_w (C, C_{tr})$ [dB]	$R_{A,1}$ [dB]	$R_{A,2}$ [dB]
Non-plastered wall	45 (-1;-4)	44	41
Plastered wall*	45 (-1;-4)	44	41

Source: Technical recommendation SYSTEM 3E EKO+ RT2023/03/01
*Wall covered on both sides with 1 cm thick cement-lime plaster

FIRE RESISTANCE CLASS

Loaded to 100% of the design resistance*	REI 240 + M
--	-------------

Source: Technical recommendation SYSTEM 3E EKO+ RT2023/03/01
*Non-plastered wall



Harmonised standard EN 771-3:2011+A1:2015, recognised by PKN as the Polish standard PN-EN 771-3+A1:2015-10, design with the requirements of the Eurocode 6 set of standards.

SYSTEM 3E S.A.
Rondo ONZ 1
00-124 Warsaw

KRS: 0000796932
NIP: 5252796952
REGON: 383992453

contact@system3e.com
+48 533 344 918
www.system3e.com

TECHNICAL CARD

INTERNAL 175

Elements designed for the erection of partition walls in houses and commercial buildings.



ECO-FRIENDLY
CONSTRUCTION

INTERNAL WALL
BASE ELEMENT

D1 175

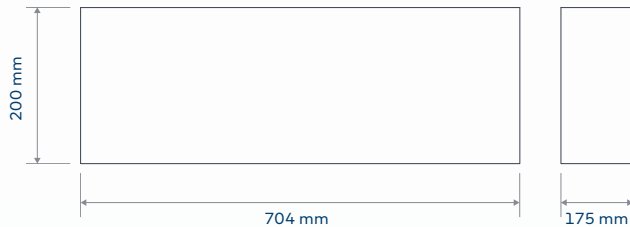
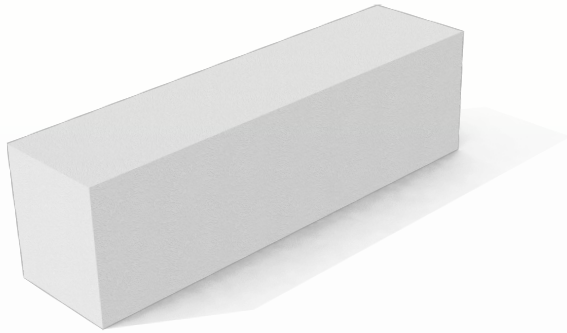

Properties of the D1 175 element

Length:	704 mm
Height:	200 mm
Width:	175 mm
Weight of single piece:	13,31 kg/el.
Deviations:	D4
Flatness of laying surface:	≤ 1,0 mm
Parallelism of laying surface:	≤ 1,0 mm

INTERNAL WALL
HALF ELEMENT

D½ 175

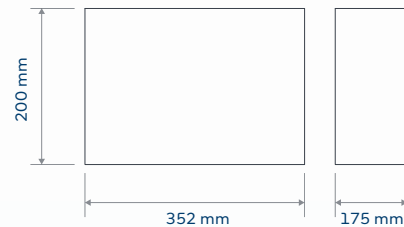
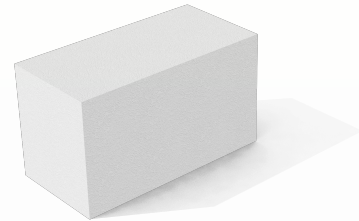



Properties of the D½ 175 element

Length:	352 mm
Height:	200 mm
Width:	175 mm
Weight of single piece:	6,66 kg/el.
Deviations:	D4
Flatness of laying surface:	≤ 1,0 mm
Parallelism of laying surface:	≤ 1,0 mm

Source: Declaration of performance S3E.D1 175/I/01/21 and S3E.D1/2 175/I/01/21

 SYSTEM 3E
load-bearing wall

 SYSTEM 3E
INTERNAL 175
internal walls

 SYSTEM 3E
INTERNAL 115
internal walls

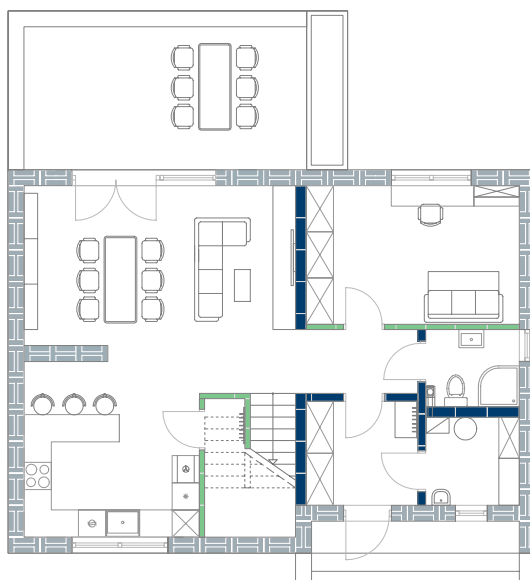

SYSTEM 3E technology in practice



QUICK ASSEMBLY



ACOUSTIC COMFORT



ECOLOGICAL MATERIAL



LIGHTWEIGHT WALL CONSTRUCTION

TECHNICAL CARD

INTERNAL 175

Elements designed for the erection of partition walls in houses and commercial buildings.



ECO-FRIENDLY
CONSTRUCTION

PERFORMANCE CHARACTERISTICS

Density	390 kg/m ³
Thermal conductivity coefficient (λ)	0,084 W/(m·K)
Characteristic compressive strength	$\geq 2,0$ N/mm ²
Water absorption due to capillary rise	after 10': ≤ 50 g/m ² · s ^{0,5}
Dimensional stability. Moisture expansion	$\leq 0,35$ mm/m
Reaction to fire	A1
Water vapour permeability, diffusion resistance factor	≤ 15
Freeze/thaw durability	20 cycles

Source: Declaration of Performance S3E.D1 175/I/01/21 and S3E.D1/2 175/I/01/21

TECHNICAL CONSTRUCTION PARAMETERS

Characteristic value of the tensile strength at bending in the case of failure in the perpendicular plane	$f_{xk \perp} = 0,14$ N/mm ²
Characteristic value of the tensile strength at bending for failure in the parallel plane	$f_{xk \parallel} = 0,10$ N/mm ²
Characteristic shear strength of masonry	$f_{vk} = 0,11$ N/mm ²

Source: Declaration of Performance S3E.D1 175/I/01/21 and S3E.D1/2 175/I/01/21

LOGISTICAL DATA

Consumption of 1 m ²	7,02 el./m ²
Wall area per pallet	5,98 m ²
Number of elements per pallet	to 40 el.
Approximate weight of the pallet	550 kg
Weight of a single element D1 175	13,31 kg/el.
Weight of a single element D½ 175	6,66 kg/el.
Weight of 1 m ²	93,4 kg/m ²

ACOUSTIC PROPERTIES

	Rw (C, Ctr) [dB]	RA,1, [dB]	RA,2 [dB]
Non-plastered wall	42 (-1;-5)	41	37
Plastered wall*	43 (-1;-3)	42	39

*Wall covered with 1 cm thick gypsum plaster on both sides

FIRE RESISTANCE CLASS

Non-load bearing wall	EI 120
-----------------------	--------



Harmonised standard EN 771-3:2011+A1:2015, recognised by PKN as the Polish standard PN-EN 771-3+A1:2015-10, design with the requirements of the Eurocode 6 set of standards

SYSTEM 3E S.A.
Rondo ONZ 1
00-124 Warsaw

KRS: 0000796932
NIP: 5252796952
REGON: 383992453

contact@system3e.com
+48 533 344 918
www.system3e.com

TECHNICAL CARD

INTERNAL 115

Elements designed for the erection of partition walls in houses and commercial buildings.



ECO-FRIENDLY
CONSTRUCTION

INTERNAL WALL
BASE ELEMENT

D1 115

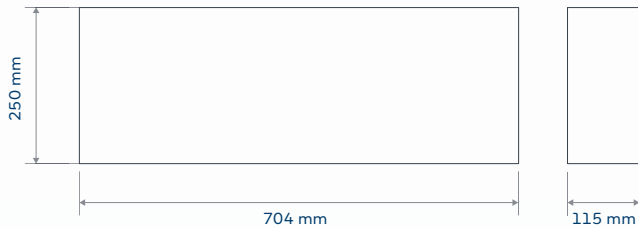
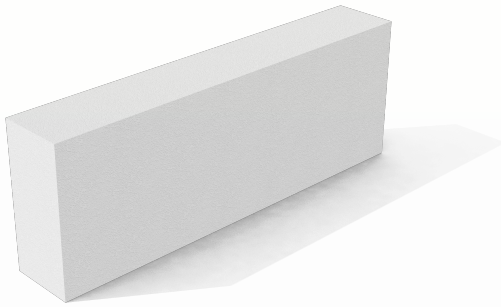

Properties of the D1 115 element

Length:	704 mm
Height:	250 mm
Width:	115 mm
Weight of single piece:	10,8 kg/el.
Deviations:	D4
Flatness of laying surface:	≤ 1,0 mm
Parallelism of laying surface:	≤ 1,0 mm

INTERNAL WALL
HALF ELEMENT

D½ 115

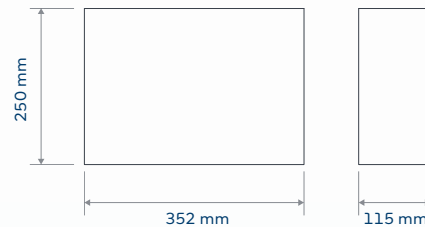
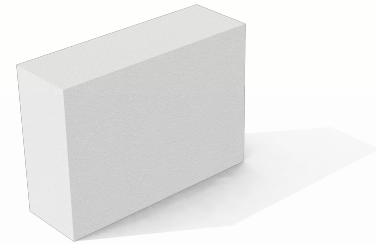



Properties of the D½ 115 element

Length:	352 mm
Height:	250 mm
Width:	115 mm
Weight of single piece:	5,4 kg/el.
Deviations:	D4
Flatness of laying surface:	≤ 1,0 mm
Parallelism of laying surface:	≤ 1,0 mm

Source: Declaration of performance S3E.D1 115/I/01/21 and S3E.D1/2 115/I/01/21

 SYSTEM 3E
load-bearing wall

 SYSTEM 3E
INTERNAL 175
internal walls

 SYSTEM 3E
INTERNAL 115
internal walls



SYSTEM 3E technology in practice



QUICK ASSEMBLY



ACOUSTIC COMFORT



ECOLOGICAL MATERIAL



LIGHTWEIGHT WALL CONSTRUCTION

TECHNICAL CARD

INTERNAL 115

Elements designed for the erection of partition walls in houses and commercial buildings.



ECO-FRIENDLY
CONSTRUCTION

PERFORMANCE CHARACTERISTICS

Density	390 kg/m ³
Thermal conductivity coefficient (λ)	0,084 W/(m·K)
Characteristic compressive strength	$\geq 2,0$ N/mm ²
Water absorption due to capillary rise	after 10': ≤ 50 g/m ² · s ^{0,5}
Dimensional stability. Moisture expansion	$\leq 0,35$ mm/m
Reaction to fire	A1
Water vapour permeability, diffusion resistance factor	≤ 15
Freeze/thaw durability (20 cycles)	no damage

Source: Declaration of Performance S3E.D1 115/I/01/21 and S3E.D1/2 115/I/01/21

TECHNICAL CONSTRUCTION PARAMETERS

Characteristic value of the tensile strength (when the upper edge is restrained) at bending in the case of failure in the perpendicular plane	$f_{vk \perp} = 0,14$ N/mm ²
Characteristic value of the tensile strength (when the upper edge is restrained) at bending for failure in the parallel plane	$f_{vk \parallel} = 0,10$ N/mm ²
Characteristic shear strength of masonry	$f_{vk} = 0,10$ N/mm ²

Source: Declaration of Performance S3E.D1 115/I/01/21 and S3E.D1/2 115/I/01/21

LOGISTICAL DATA

Consumption of 1 m ²	5,65 el./m ²
Wall area per pallet	8,85 m ²
Number of elements per pallet	to 50 el.
Approximate weight of the pallet	550 kg
Weight of a single element D1 115	10,8 kg/el.
Weight of a single element D½ 115	5,4 kg/el.
Weight of 1 m ²	61,02 kg/m ²

ACOUSTIC PROPERTIES

	R_w (C, C _v) [dB]	$R_{A,1}$ [dB]	$R_{A,2}$ [dB]
Non-plastered wall	39 (-1;-2)	38	37
Plastered wall*	40 (-1;-4)	39	36

*Wall covered with 1 cm thick gypsum plaster on both sides

FIRE RESISTANCE CLASS

Not loaded wall	EI 120
-----------------	--------

